

OLD TESTAMENT 2

UNIT ONE INTRODUCTION TO THE FORMER PROPHETS

THE PLACE OF THE FORMER PROPHETS IN THE OLD TESTAMENT

- These books are the Bible's account of Israel's history from its entry into the land of Canaan (Joshua) to its removal from the land (end of 2 Kings).
- In the Hebrew Bible these books appear with Isaiah, Jeremiah, Ezekiel and the Twelve minor prophets.
- Even when not dealing directly with prophets they provide a background to books like Isaiah and Jeremiah.
- Despite their historical background, they are more than mere chronicles of historical events.
- They are especially concerned with God's relationship with Israel and its expression in judgement and salvation.
- We are reminded again and again that it is the prophetic word that shapes history because it is the word of God.

ISRAEL IN THE PERIOD COVERED BY THE FORMER PROPHETS

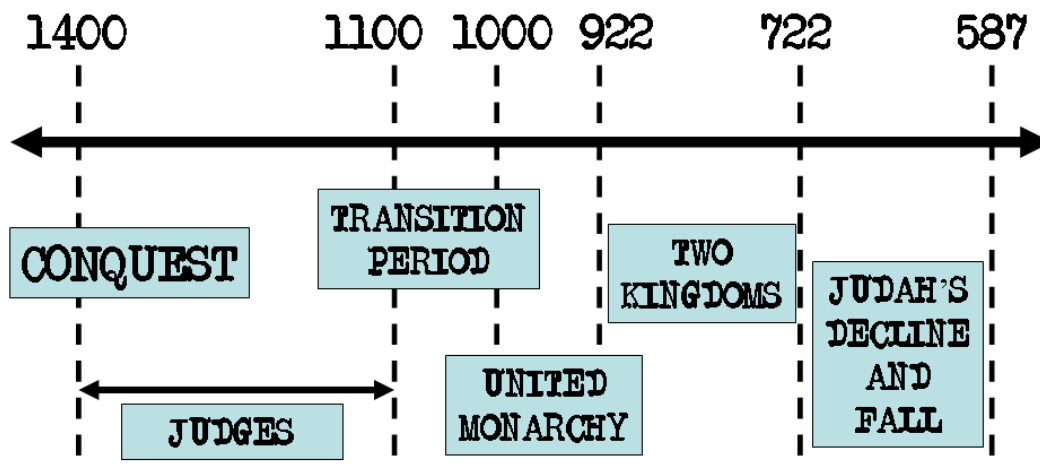

- **THE PERIOD OF THE CONQUEST (c. 1400BC)**
 - The date is linked to the Exodus, and both lead to some historical difficulties.
 - Archaeological evidence suggests decisive assaults in Canaan in the late 13th century.
 - This leads some to favour a late date for the exodus (1280-1240BC), but Old Testament chronology suggests a 15th century date.
 - Canaan was at that time divided between various rulers and in a chaotic situation, therefore very vulnerable to attack.

- **THE PERIOD OF THE JUDGES (1400-1100BC)**
 - Israel was divided into tribal areas, conquests by other groups such as the Midianites or Philistines only tended to directly affect one or two tribes.
 - The tribes were united by their history and allegiance to the LORD.
 - An annual festival reminded the people of their identity and the obligations that it brought.
 - Administration was provided by the elders of the clans and tribes, with more serious matters settled centrally.
 - Ad hoc assemblies of the tribes dealt with areas of common concern such as threats of enemy attack.
 - A fresh army had to be raised to face each threat – many judges rose to their position due to inspiring leadership on these occasions.
 - The system rarely worked as smoothly as intended, there was little effective unity in this period.
 - Being mixed in with unconquered Canaanites led to the worship of pagan gods.
 - There was disagreement and fighting amongst the tribes, providing more of a threat than any external attack.
 - There were faithful Israelites, but Judges focuses on the many crises Israel faced.

- **THE PERIOD OF TRANSITION (1100-1000BC)**
 - Two figures dominate this period – Samuel, the last of the judges, and Saul, the first of the kings.
 - Israel was in transition from a tribal confederacy to a united kingdom – this period is covered in 1 Samuel.
 - The change was partly due to the threat from the Philistines – people felt that Israel could be better defended by a king with a standing army.

- **THE UNITED MONARCHY (1000-922BC)**
 - Effective central administration was established under David, and Jerusalem became the political and religious centre.
 - Israel became a regional power, with Solomon being able to capitalise on what David had achieved through taxation and trading.
 - Solomon however lacked David's military skills, and often favoured the south over the north, leaving Israel more divided and open to outside threats.

- **THE PERIOD OF TWO KINGDOMS (922-722BC)**
 - After the death of Solomon the northern tribes broke away under Jeroboam I.
 - This greatly weakened both Israel in the north and Judah in the south.

- Judah was threatened by Edom and Moab, and Israel by Syria – Judah with its continuing Davidic dynasty was the more stable.
- As Assyrian power grew, smaller states tried to form coalitions to resist but eventually Israel's capital Samaria fell in 722BC.
- **JUDAH'S DECLINE AND FALL (722-587BC)**
 - Despite having the Assyrian empire reaching its borders, Judah survived for another 135 years – attempts at invasion failed.
 - The Assyrian empire declined, but was replaced as the dominant power by a revitalised Babylonia.
 - After revival under Josiah, later kings were too corrupt to provide effective leadership, and the end came in 587BC with Jerusalem destroyed and the people taken into exile.

THE ORIGINS AND DATES OF WRITING OF THE FORMER PROPHETS

- The traditional view is that these books were written by prophets.
- Traditionally, Joshua wrote the book that bears his name – he was clearly a prophet and a covenant mediator.
- Many events in Joshua's life closely parallel Moses' life – the crossing of the Jordan compared to the crossing of the Red Sea and Joshua's direct encounter with God at Jericho.
- The rabbis regarded Samuel as the author of Judges and much of Samuel, even though he died before some of the events in 2 Samuel took place.
- The traditional view was that Nathan and Gad extended Samuel's work, and that Jeremiah wrote the book of Kings.
- 2 Chronicles makes clear references to prophets as writers whose work was later used by other writers.
- There is much truth in the traditional view but also a number of problems, and it is probably a simplification.
- Samuel may well have written much of Judges, but the truth is probably more complex than this view suggests.
- Much of the material seems to be from sources very close to the events, and from oral or written 'hero-stories'.
- There is considerable evidence through Judges of early source material which has been shaped by an editor.
- It is hard to say when the final shaping took place.
- Most scholars believe that Deuteronomy to Kings were originally one long piece of historical writing, possibly written after the fall of Jerusalem in 587BC – the 'Deuteronomistic' history.
- The 480 years from the exodus to the building of the temple seems to fit into a chronological scheme which spans Deuteronomy to 2 Kings.
- Scholars are divided over whether this history was originally one book or was divided up from the beginning.
- Given its close relationship to other books, Judges probably took its final form during the Babylonian exile.

THE MAJOR THEMES OF THE FORMER PROPHETS

- **APOSTASY**

- The former prophets identify unfaithfulness to Yahweh as the cause of the disasters of 722 and 587BC.
- This mainly took the form of worshipping pagan gods.
- The apostasy worsened over the years, with kings seen as the main contributors through their religious policies.
- Prophets continually warned of the dangers, but these warnings were largely unheeded.

- **JUDGEMENT**

- In view of Israel's persistent apostasy, the disasters of 722 and 587BC are seen as thoroughly just divine judgements.
- They were the fulfilment of the numerous warnings given by the prophets.
- The destruction of Jerusalem may have led some to think that Yahweh had been overcome by foreign gods, but the Former Prophets show that this was not the case – he had done exactly as he said he would.

- **GRACE**

- The Former Prophets also record many instances of Yahweh's grace towards Israel.
- Fundamental to this is the gift of the land promised to their ancestors.
- When the people slid into apostasy, Yahweh came to their rescue when they cried out to him, even though they did not deserve it.
- Yahweh promises to establish David's dynasty for ever – this was a focus for hope in the dark days of the exile.